



FreeAir

Two-way active chilled beam for exposed installation



Overview

Description

FreeAir is a water- and air-based induction unit with bidirectional air diffusion, recommended for a wide range of commercial applications—such as office buildings, restaurants, retail stores, museums, and hotels—where a combination of ventilation, cooling, and/or heating is required. Featuring an exceptionally slim, elegant design, FreeAir is specifically developed for exposed installations and is mounted directly under the ceiling. For enhanced flexibility and efficiency, FreeAir can be equipped with a digital controller, designed for DCV (Demand-Controlled Ventilation) applications.

Function

The function of active chilled beams is based on the well-known induction principle. The primary (dried) air from the air handling unit is injected into the plenum box within the active chilled beam and distributed through specially shaped nozzles. As the air is discharged through these nozzles, the high-velocity air jets above the coil create a low-pressure zone, which draws ambient room air through the coil. As it passes the coil fins, this drawn-in air is conditioned (cooled or heated) according to the water temperature in the coil. The conditioned air then mixes with the air jets before being discharged back into the occupied space. The careful placement and shape of the nozzles have a major impact on both the performance of the chilled beam and its sound emissions. It is important that the primary air from the air handling unit is sufficiently dry to maintain a low indoor dew point and prevent condensation. Because water is a more effective medium for heat transfer compared to air, chilled beams are an outstanding energy-efficient solution, reducing the overall energy needed for cooling, heating, and ventilation.



Main characteristics

- Water- and air-based system
- Visible installation
- Bidirectional air diffusion
- Elegant exterior design
- Exceptionally slim profile with a height of only 120 mm
- Silent, energy-efficient, and draught-free operation
- Optimal thermal comfort
- High flexibility with AirFlex air deflectors
- Design allows for multiple units to be connected in sequence
- Optional control solution

Standard sizes

1500x600, 1800x600, 1800x600, 2100x600, 2400x600, 2700x600, 3000x600

Airflow range

36 - 126 m³/h (10-35 l/s)

Table 01 - Quick selection

Size	Airflow l/s [m ³ /h]	Pressure [Pa]	Cooling capacity* [W]		
			Air	Water	Total
1500	10-15	50	120	498	618
	[36-90]	100	300	830	1130
1800	10-30	50	120	570	690
	[36-108]	100	360	960	1320
2100	15-35	50	180	694	874
	[54-126]	100	420	1096	1516
2400	15-35	50	180	740	920
	[54-126]	100	420	1204	1624
2700	15-35	50	180	756	936
	[54-126]	100	420	1305	1725
3000	15-35	50	180	772	952
	[54-126]	100	420	1405	1825

*at ΔT = 10 °K

Features

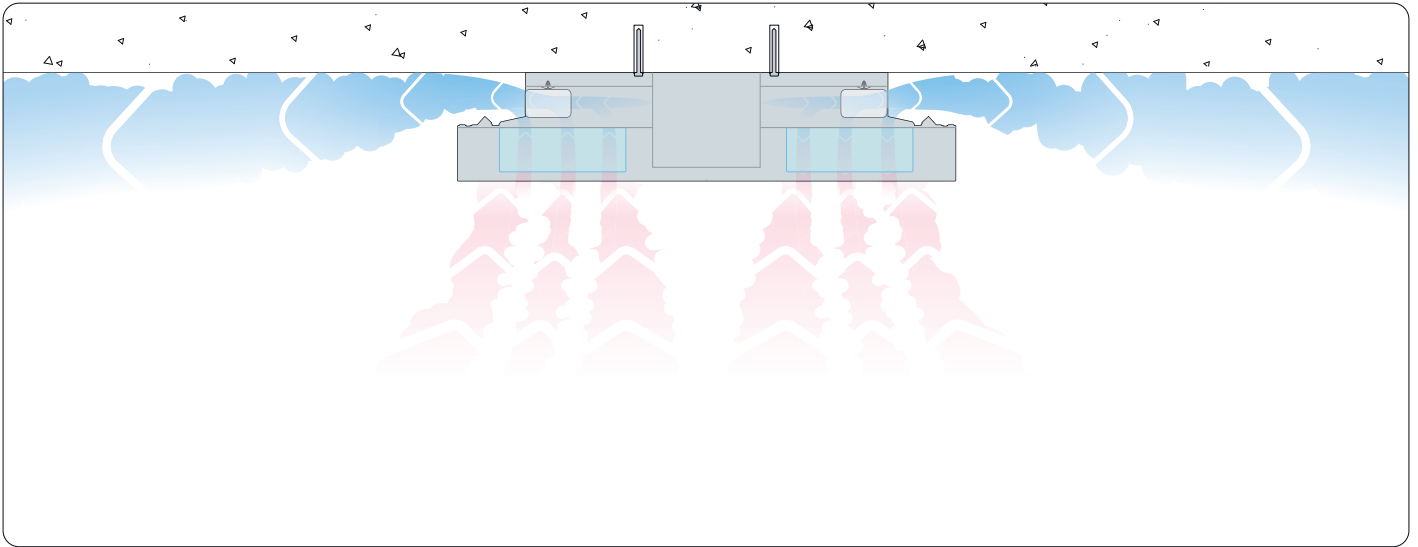

Figure 01 - Inductive effect

Applications

Chilled beams are a versatile ventilation solutions that provide efficient heating, cooling, and ventilation for various commercial settings. They are particularly effective in environments where maintaining high indoor air quality and energy efficiency is important. Applications include office buildings, shopping malls, retail stores, restaurants, and hotels.

Applied materials and finish

The plenum box and the visible, fold-down front panel design are made of galvanized steel. The front panel is powder coated in standard white RAL 9003 color (or in any other RAL color requested by the customer). The heat exchanger fins are made of aluminium, the piping is made of copper. The AirFlex air deflectors are made of polyamid (PA) plastic. The front panels are produced with circular perforation as standard.

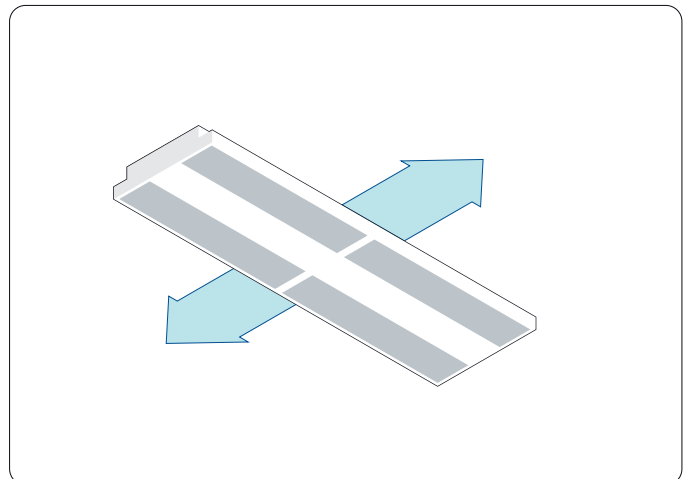

Figure 02 - Two-way air diffusion

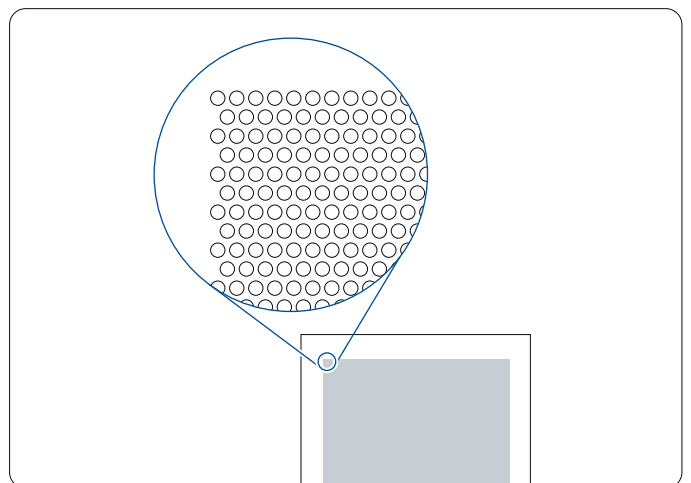

Figure 03 - Circular perforation

AirFlex - adjustable air deflectors

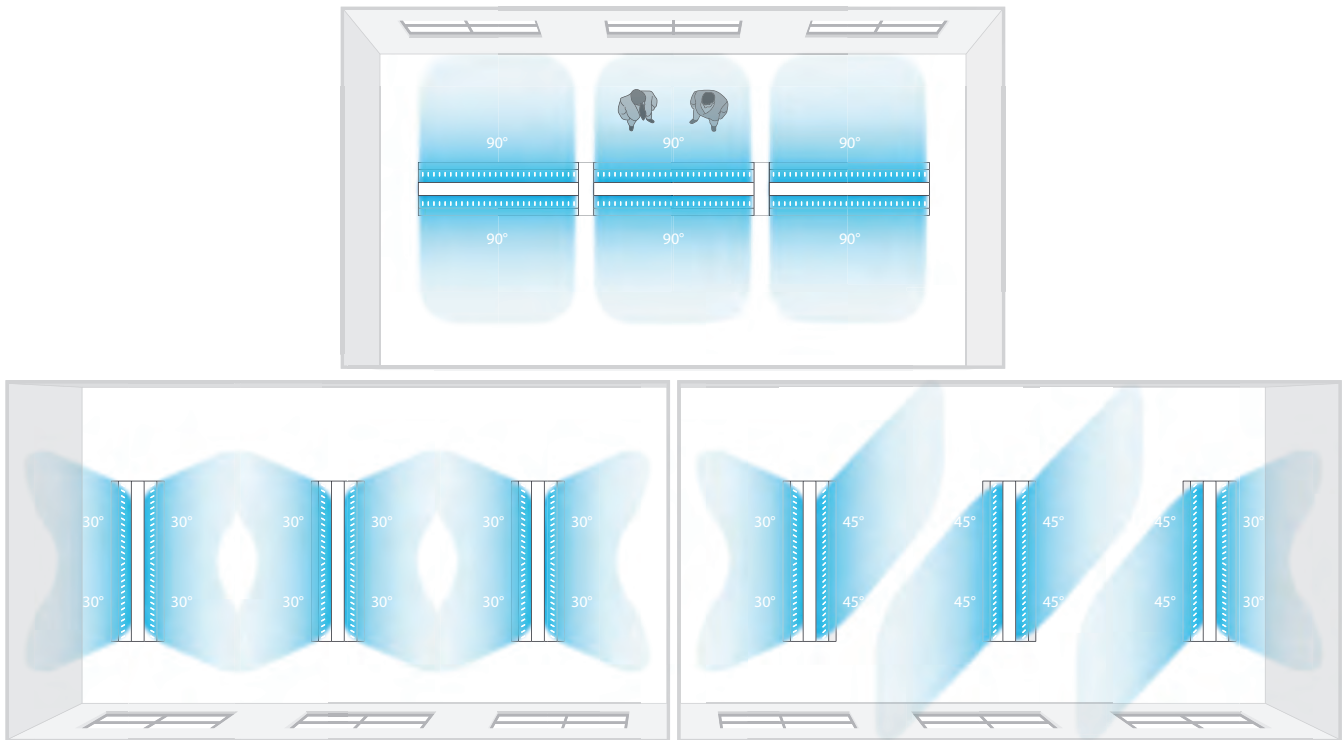

Figure 04 - AirFlex - different airflow settings Note: if the angle of the deflectors is larger than 30°, the performance may decrease

FreeAir is equipped with AirFlex air deflectors, which can be manually and individually adjusted on each side of the air slots, as standard option. AirFlex allows the operator to easily adjust the direction and throw distance of the discharged conditioned air. With the fine-tuning capabilities of the AirFlex deflectors, in combination with the variable nozzles, a highly flexible, pleasant and draught-free indoor climate is easily achieved.

- Less risk of draft
- Shorter throw length
- Individually adjustable

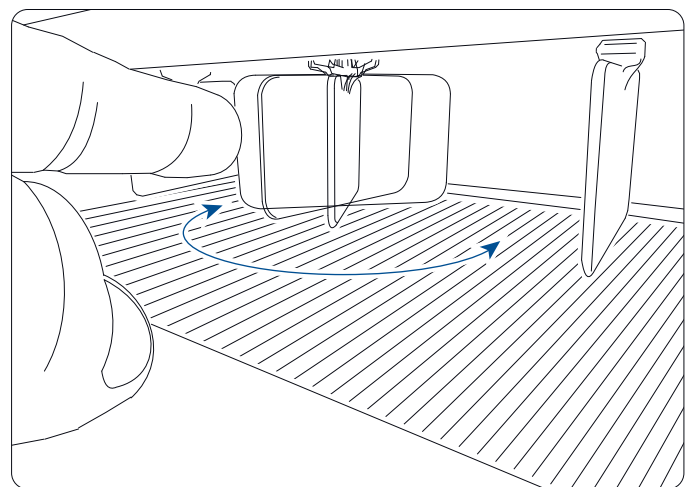

Figure 05 - AirFlex - Adjustable air deflectors

Installation and commissioning

Front panel

Opening the Front Panel: Pull the locking tabs in the direction indicated by the arrows (See: Figure 03) to open the front panel.

Attention! After unlocking the latches, the front panel will immediately open on its own. Beware of the sudden opening, and make sure to hold the panel to slow its opening in order to prevent accidents and protect the product.

The front panels are secured by anti-fall cables, which only allow them to open to a certain point.

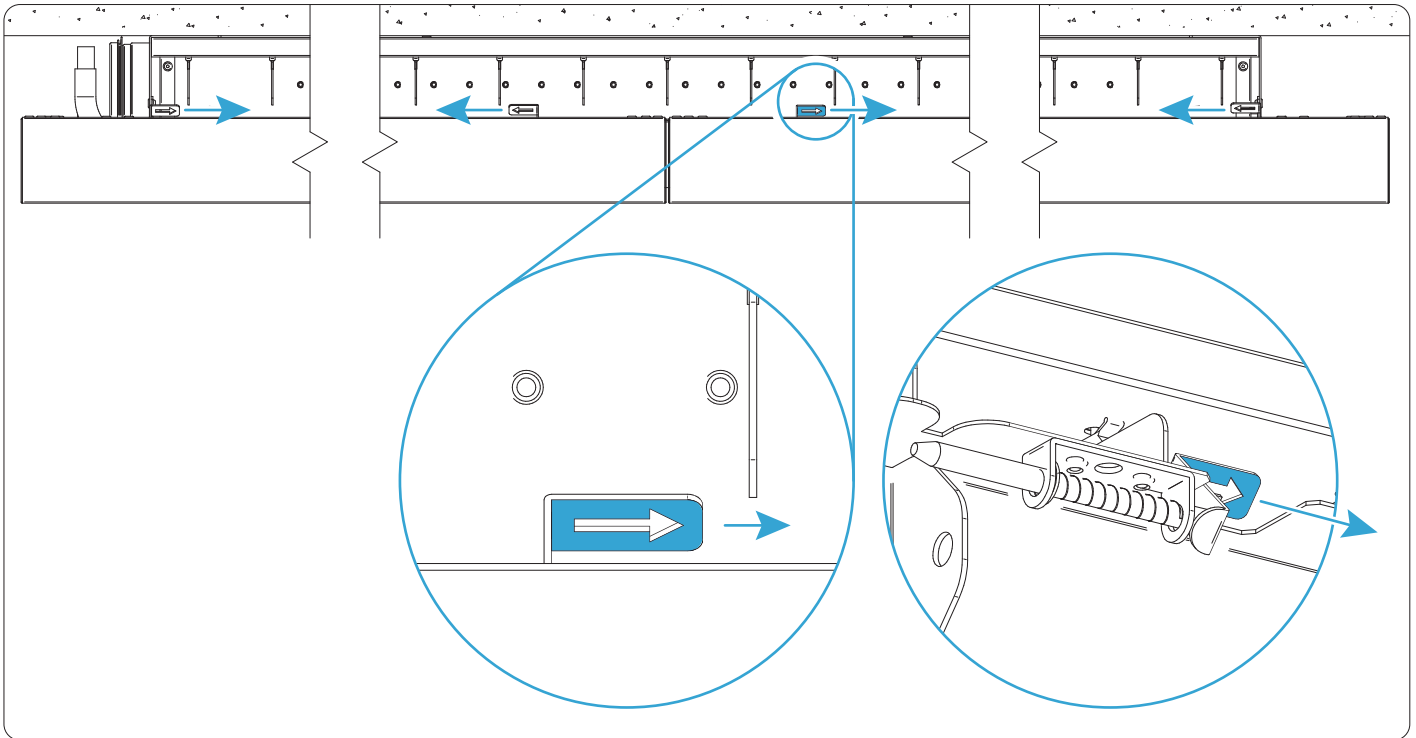

Figure 06 – Opening the front panel

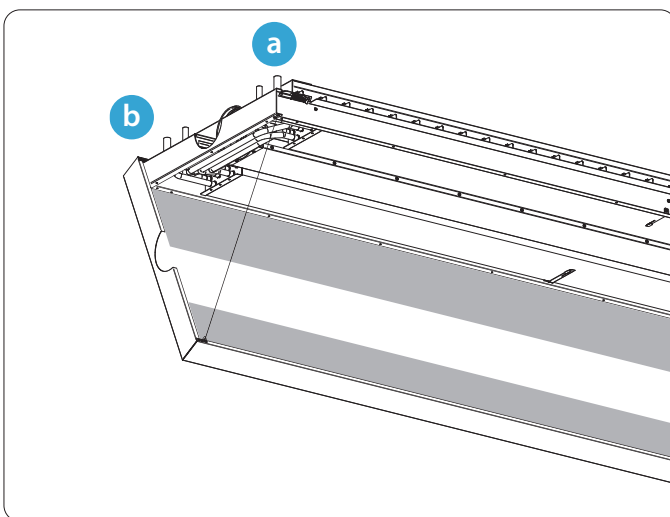

Figure 07 - Product with front panel opened

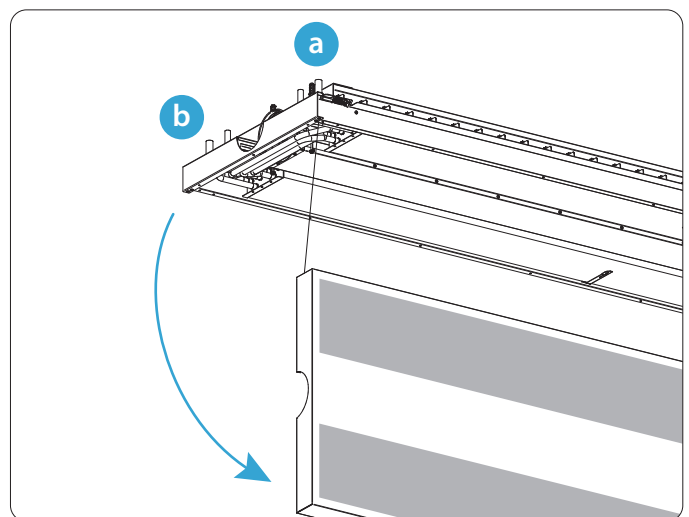

Figure 08 - Product with front panel removed

Removing the front panel: Unlock the latches on the 'b' side as well, then lift off the front panel. The cables will hold it in a suspended position.

Reinstalling and closing the front panel: Lift the front panel back into place on the 'b' side, then secure the latches. When closing the front panel, make sure that the latches are properly secured: they should snap back into place with an audible click.

Mounting

Marking

To install the device, first, mark the mounting points on the ceiling. Draw the product's longitudinal axis on the ceiling and mark the center of the product along that axis. Based on the dimension table (See: Dimensions), measure and mark the L1, L2, and L3 dimensions corresponding to the appropriate product on the ceiling.

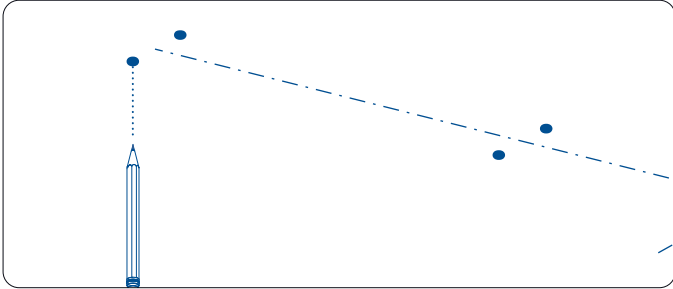

Figure 09 - Marking the mounting holes

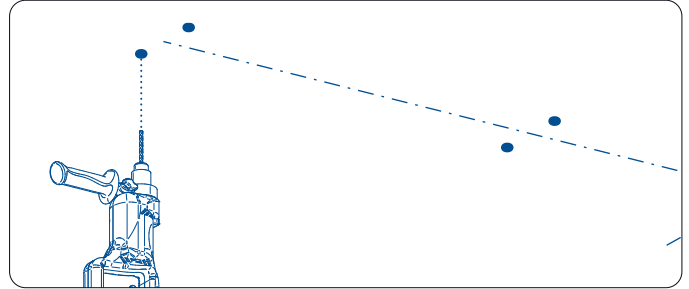

Figure 10 - Drilling the mounting points

Securing the product

Lift the product to the mounting points. Before lifting, open and remove the front panel(s). Insert the fasteners through the provided openings in the product.

Attention! During installation, make sure that the product is securely supported!

Tighten the fasteners using a manual or powered screwdriver. After securing the product, place and then close the front panel(s).

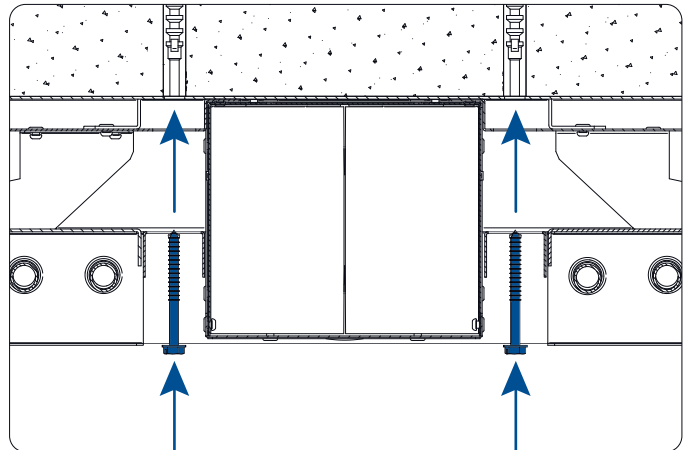

Figure 11 - Installing the fasteners

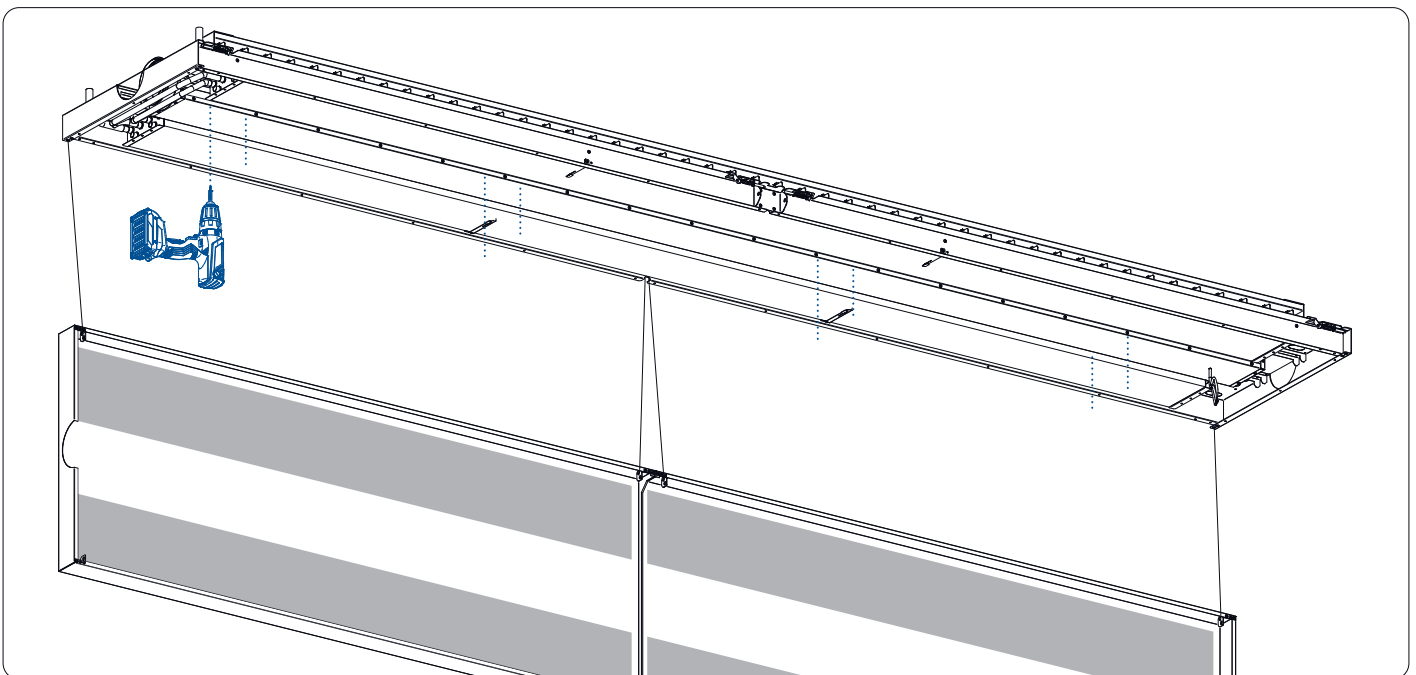

Figure 12 - Securing the fasteners

Technical data

Sound

Sound effect level / octave band: L_W [dB]

Sound level: L_{PA} [dB(A)]

Correction: K_{OK} [dB]

$$L_W = L_{PA} + K_{OK}$$

The measurements have been performed in accordance with ISO 9614-2 and ISO 11691: 1995.

Table 02 - Correction K_{OK} [dB]

Size [mm]	Medium frequency [Hz]							
	63	125	250	500	1000	2000	4000	8000
1500	+2	-4	-3	+2	+1	-6	-19	-28
1800	+6	-1	-4	+1	+1	-4	-15	-25
2100	+6	-1	-4	+1	+1	-4	-15	-25
2400	+3	-1	-7	-4	-1	0	-19	-30
2700	+3	-1	-7	-4	-1	0	-19	-30
3000	+2	-2	-4	0	0	-1	-17	-27

Tol. ± 3 dB

Table 03 - Sound attenuation [dB]

Size [mm]	Medium frequency [Hz]							
	63	125	250	500	1000	2000	4000	8000
1500	24	19	11	4	6	12	16	19
1800	25	21	13	6	5	12	16	19
2100	25	21	13	6	5	12	16	19
2400	24	21	13	4	5	11	16	19
2700	24	21	13	4	5	11	16	19
3000	23	20	12	4	5	12	17	20

Tol. ± 3 dB

Table 04 - Sound pressure level L_{PA}

Room capacity	Room type	Correction
25 m ³	Hard	+2 dB
25 m ³	Attenuated	-2 dB
150 m ³	Hard	-3 dB
150 m ³	Normal	-5 dB
150 m ³	Attenuated	-7 dB

The sound pressure level L_{PA} [dB(A)] applies to an equivalent surface of 10 m², which corresponds to an attenuation of 4 [dB] in a 25 m³ room with normal attenuation. Please see the chart to the right for correction examples of different room types.

Table 05 - Sound level

Size [mm]	Primary airflow		Soundlevel, dB(A) at given pressure [Pa]					
	[l/s]	[m ³ /s]	Cooling			Heating		
			50 [Pa]	75 [Pa]	100 [Pa]	50 [Pa]	75 [Pa]	100 [Pa]
1500	10	[36]	<20	<20	<20	<20	<20	<20
1800			<20	<20	<20	<20	<20	<20
1500	15	[54]	<20	<20	<20	<20	<20	<20
1800			<20	<20	<20	<20	<20	<20
2100			<20	<20	<20	<20	<20	<20
2400			<20	<20	<20	<20	<20	<20
2700			20	21	20	21	20	21
3000			21	20	21	20	21	20
1500	20	[72]	<20	<20	<20	<20	<20	<20
1800			<20	<20	<20	<20	<20	<20
2100			<20	<20	<20	<20	<20	<20
2400			<20	<20	<20	<20	<20	<20
2700			20	21	22	20	21	22
3000			<20	22	25	<20	22	25
1500	25	[90]	20	21	22	20	21	22
1800			20	22	24	20	22	24
2100			21	22	22	21	22	22
2400			<20	<20	20	<20	<20	20
2700			21	22	23	21	22	23
3000			<20	24	27	<20	24	27
1800	30	[108]	23	26	27	23	26	27
2100			21	22	23	21	22	23
2400			20	20	22	20	20	22
2700			23	24	25	23	24	25
3000			22	25	28	22	25	28
2100			22	23	24	21	23	24
2400	35	[126]	21	22	24	22	22	24
2700			25	26	27	25	26	27
3000			26	27	29	26	27	29

Dimensions

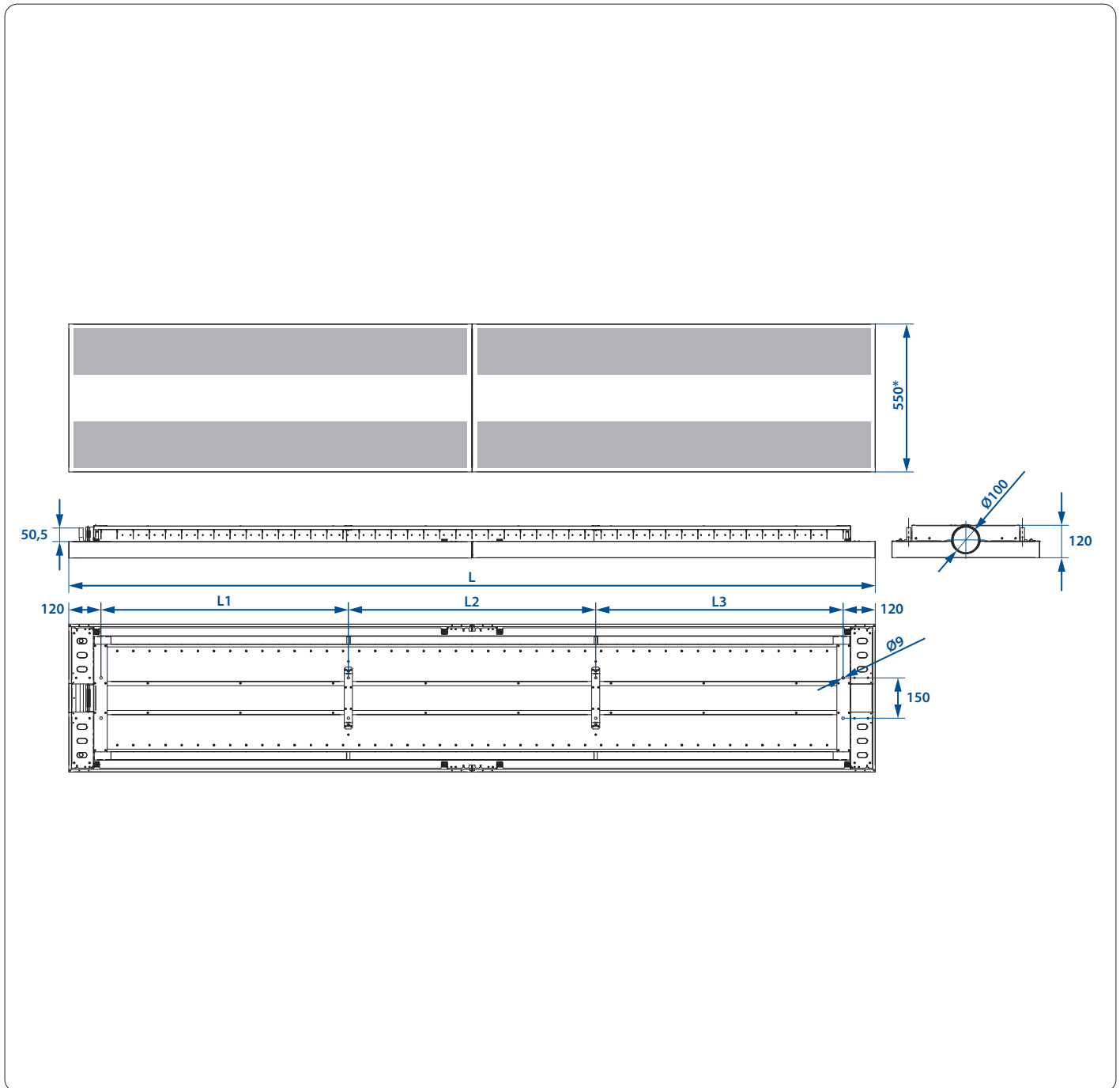

Figure 13 - Dimensions

Table 06 - Dimensions

Size	Dimensions [mm]				Weight [kg]
	L	L1	L2	L3	
1500	1500	630	630	–	22
1800	1800	780	780	–	
2100	2100	930	930	–	
2400	2400	720	720	720	
2700	2700	820	820	820	
3000	3000	920	920	920	41,5

Table 07 - Water connection

Type	Number of water circuits	Water-side connection [mm]			
		For cooling water		For heating water	
		in [CW _{in}]	out [CW _{out}]	in [HW _{in}]	out [HW _{out}]
<2100	One circuit	Ø 12		Ø 12	
≥2100	Two circuits	Ø 15			

Connections

Vertical water connection

Table 08 - Vertical (top) water connection

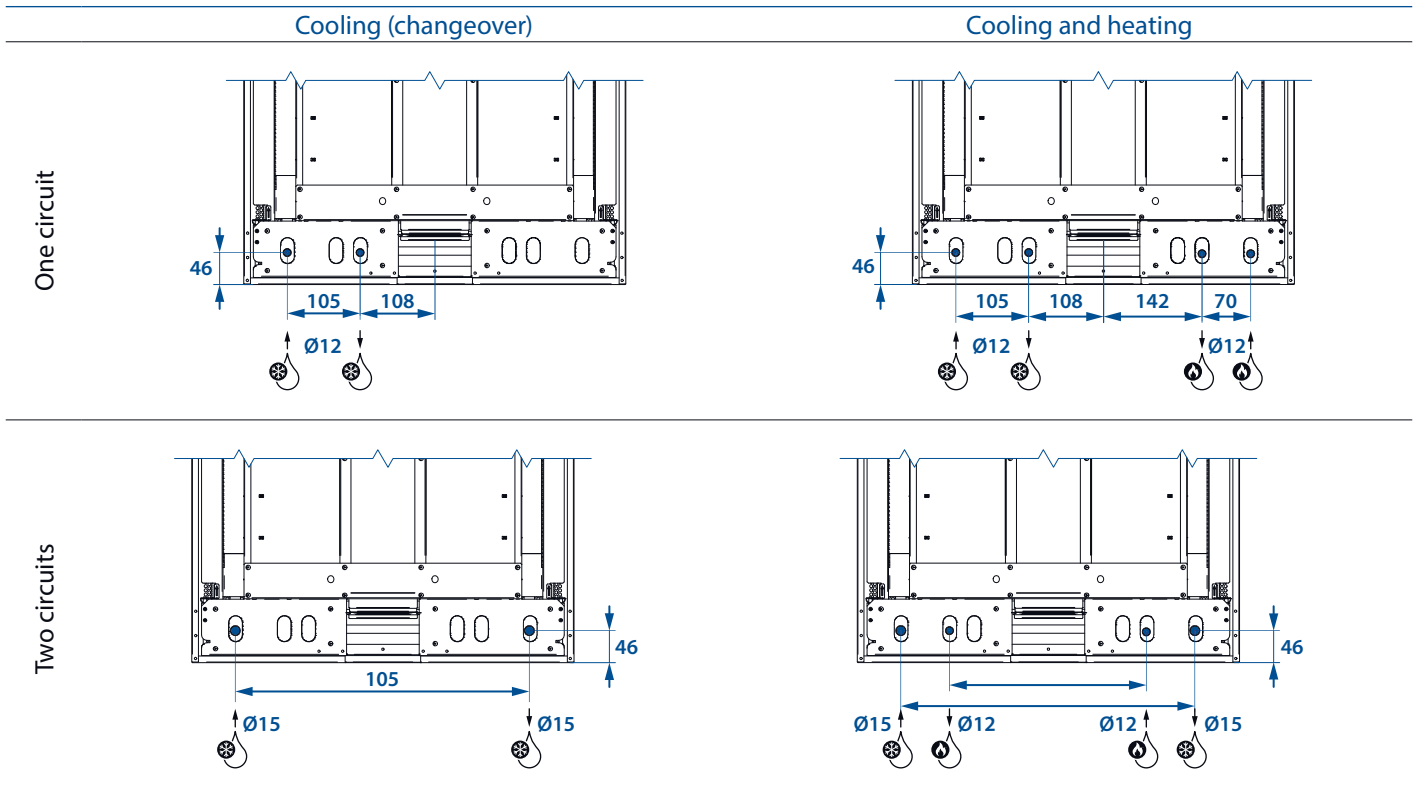

Horizontal water connection

Table 09 - Horizontal (side) water connection

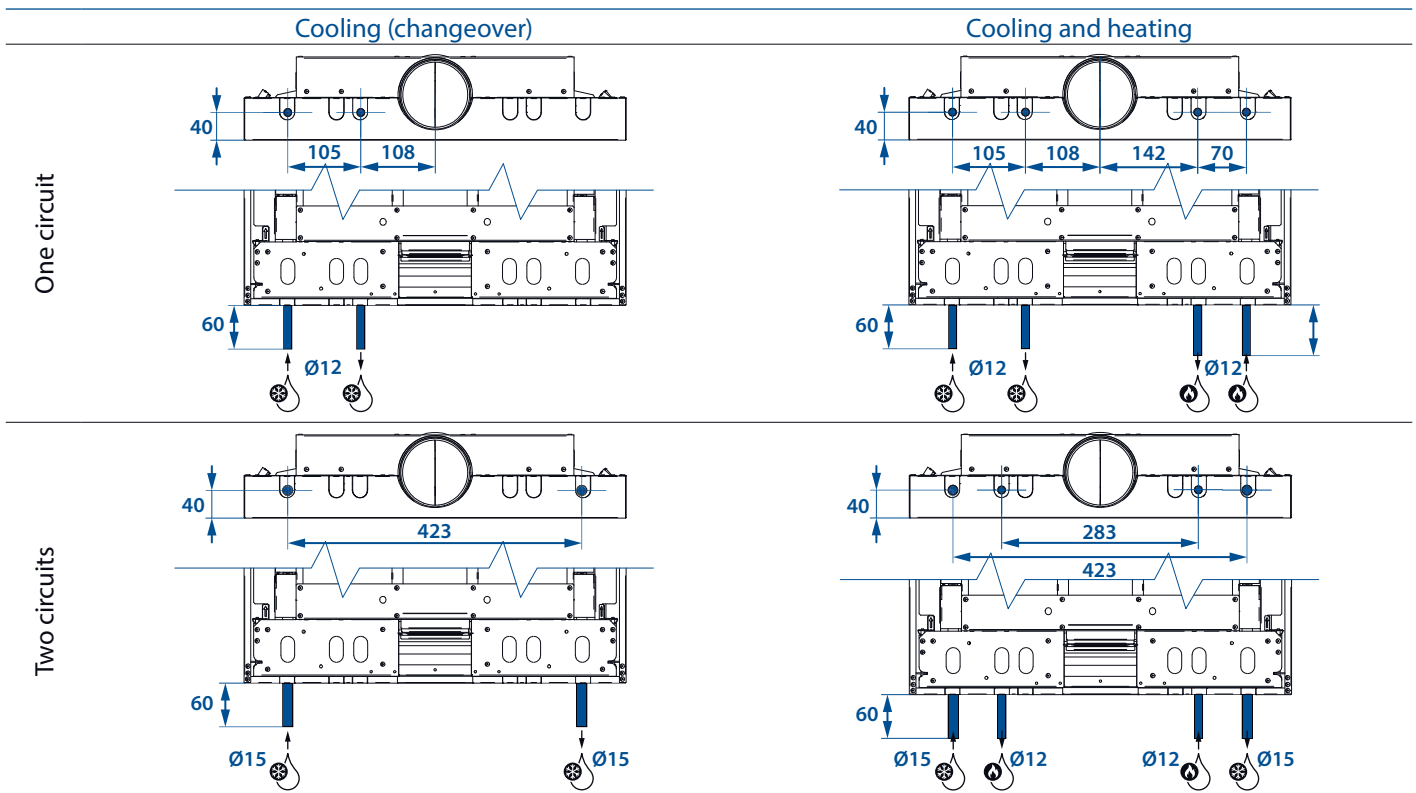

Ordering code

Table 10 - FreeAir ordering code

FA	XX	-XX	X	X	X	X	X	-XXX	XXXXXXX
Product acronym	Size (mm)	Coil type	Nozzle type	Direction of connections	Air Connection	Additional	Extra character	Electronics	(Color) in case of non-standard color
	1500: 15 1800: 18 2100: 21 2400: 24 2700: 27 3000: 30	1-round cooling: C1 2-round cooling: C2 1-round cooling and heating: H1 2-round cooling and heating: H2	A1: 1 A2: 2 A3: 3 A4: 4 A5: 5 A6: 6	Only short side Same and side: A Opposite and side: B Same and top: S Opposite and top: O	1xDN100: A	Standard: A	A	Without electronics: Q00	Standard color: RAL 9003-30%

Ordering example: FA21-C21SAAA-Q00

